

TREATMENT PLANT APPROVAL 02/2025
Plumbing and Drainage Regulation 2019, part 4.



Approval

1. The **Advanced Enviro-Septic 38** (AES-38) ("the system") described in the Specifications and Drawings in the attached Schedule and manufactured by **Presby Environmental Inc. Whitefield, New Hampshire** ("the manufacturer") and supplied by **Chankar Environmental Pty Ltd** (ACN 148 175 455) ("the supplier") This transitional Treatment Plant Approval has been assessed in accordance with:
 - (a) sections 34 and 35 of the *Plumbing and Drainage Regulation 2019* and
 - (b) the Queensland Plumbing and Wastewater Code version 2024.1 that commenced on 26 April 2024.
2. A transitional Treatment Plant Approval (TPA) is granted for a **secondary quality** wastewater treatment system, subject to compliance by the manufacturer/supplier with the requirements of the *Plumbing and Drainage Act 2018* and the conditions of approval detailed below.
3. As no changes have been made to the system this approval replaces the previous approval, TPA 07/2024 issued on 26 April 2024.
4. This approval, the conditions of approval, and the Schedule comprise the entire TPA document.
5. Any modification by the manufacturer/supplier to the design, drawings or specifications scheduled to this approval must be approved by the Chief Executive.

Conditions of approval

6. The manufacture, installation, operation, service, and maintenance of the system must be in conformity with the conditions of this TPA.
7. The **secondary quality** wastewater treatment system, may only be used on premises that generate per day:
 - a) a maximum hydraulic loading of 38 L per lineal metre of AES piping system
 - b) a maximum organic loading of 300 mg/L BOD₅
 - c) a maximum total suspended solids of 300 mg/L.
8. The system must continue to meet the requirements of a secondary quality wastewater treatment system, producing the following effluent quality —
 - a) 90% of the samples taken must have a BOD₅ less than or equal to 20 g/m³ with no sample greater than 30 g/m³.
 - b) 90% of the samples taken must have total suspended solids less than or equal to 30 g/m³ with no sample greater than 45 g/m³.
9. Each system must be serviced in accordance with the details supplied in the owner's operation and maintenance manual.
10. The system design is based upon **secondary quality** effluent design loading rate as defined in AS/NZ1547 using the Advanced Enviro-Septic (AES) Design Calculator prepared by a qualified designer. System designs must be verified and signed by the supplier before being submitted to the Local Government.

Initial:
Date:

[Signature]
16/1/25



TREATMENT PLANT APPROVAL 02/2025
Plumbing and Drainage Regulation 2019, part 4.

11. A septic tank conforming to AS/NZ 1546.1:2008 and sized in accordance with AS/NZ 1547:2012 for treatment of all daily flows of domestic wastewater from the premises is a component of the system. Effluent from the septic tank is to be diverted to the AES piping system prior to the system sand and basal area. The septic tank that feeds into the system must be regularly monitored and maintained (including de-sludging) in accordance with AS/NZ 1547:2012 to ensure optimum operation of the system.
12. Where gravity cannot be achieved to transfer effluent from septic tank to the AES treatment pipes:
 - (a) A pump well is to be used and sized as per AS/NZ1547:2012 and maintain at least 24-hour emergency storage above the high-water level alarm sensor.
 - (b) The pump is to be a submersible type with high level alarm as specified in both AS1546.3:2017 and AS/NZ 1547:2012. The pump shall be a Davey D25VA or equivalent, with a design flow of 40 L/min at a minimum 6 m head. Should site conditions require a higher head, then the appropriate pump model to achieve this shall be selected.
 - (c) In each situation, the design of the AES system must confirm with the manufacturer's design recommendations set out in the AES Calculator & Design and Installation Manual.
13. When granting a permit, the local government must satisfy itself that the designer's choice of the system configuration is optimal for the proposed use and site conditions and that the effluent can be retained within the land application area.
14. Each application for a compliance permit to install a system must also be accompanied by a copy of a completed AES Design Calculator Report endorsed by the supplier, showing the footprint/basal area of the proposed system and number of pipe modules for the site.
15. An inspection/sampling point must be installed permanently in the sand immediately below the half-way point of the AES piping system. Where a system is installed in a sloping basal area an additional inspection/sampling point must be installed at the lowest point of the system extension.
16. Routine maintenance of the system at set intervals, other than septic tank sludge levels, is not stipulated by the manufacturer/supplier. However, routine monitoring may be required by the Local Government. In the event of failure of the system's land application area an AES authorised person may need to follow the rejuvenation procedures set out in the manufacturer/supplier's Design and Installation Manual.
17. Where a system installed at a site, has been found not to operate satisfactorily during its service life, and as a result requires modification to achieve the required performance requirements, in particular, water quality limits, the installed system is to be modified accordingly. Any modifications including any of the supplier's rejuvenation procedure outcomes must be recorded on the service report.
18. Permitted use of the effluent is for **sub-surface absorption only**.
19. Each system must be supplied with —
 - (a) a copy of this TPA document;
 - (b) details of the system;
 - (c) instructions for authorised persons for its installation;
 - (d) a copy of the owner's manual to be given to the owner at the time of installation; and
 - (e) detailed instructions for authorised service personal for its operation and maintenance.

Initial:
Date:

Handwritten signature and date: 10/1/25



TREATMENT PLANT APPROVAL 02/2025
Plumbing and Drainage Regulation 2019, part 4.

20. At each anniversary of the TPA date, the supplier must submit to the Chief Executive a list of all systems installed in Queensland during the previous 12 months. Where the Chief Executive is notified of any system failures the Chief Executive may randomly select several installed systems for audit. The Chief Executive will notify the supplier's nominated NATA accredited laboratory which systems are to be audited for BOD₅ and TSS. The sampling and testing of the selected systems, if required, is to be done at the supplier's expense. The following results must be reported to the Chief Executive;
- a) Address of premises;
 - b) Date inspected and sampled;
 - c) Sample identification number;
 - d) BOD₅ for influent and effluent; and
 - e) TSS for influent and effluent.
21. The Chief Executive may, by written notice, cancel this approval if the manufacturer/supplier fails —
- a) to comply with one or more of the conditions of approval; or
 - b) within 30 days, to remedy a breach, for which a written notice been given by the Chief Executive.
22. This approval may only be assigned with the prior written consent of the Chief Executive.
23. Where there is any inconsistency between the content of this approval and the *Plumbing and Drainage Act 2018* (including any associated regulation and/or codes), the provisions of the *Plumbing and Drainage Act 2018* will apply and must be adhered to.
24. This approval expires on **31 December 2025** unless cancelled earlier in accordance with paragraph 21 above.

Greg Schonfelder

A/Director
Plumbing, Drainage and Special Projects

Date approved:

16 JANUARY 2025

Level 15,
53 Albert Street Brisbane
GPO Box 2457, Brisbane Qld 4001
Website www.business.qld.gov.au

Initial:
Date:

TREATMENT PLANT APPROVAL 02/2025
Plumbing and Drainage Regulation 2019, part 4.



SCHEDULE

AES - 38

Attachment 1 – AES – Operators manual



**Advanced Enviro-Septic
Owner's Manual**

Head Office

Chankar Environmental Pty Ltd
62 Rene Street
Noosaville QLD 4566

(07) 5474 4055
www.enviro-septic.com.au
info@enviro-septic.com.au



December 2011

1

Initial:
Date:

Initial:
Date:
6/6/12

User's Guide – Enviro-Septic System

Important Security instructions



It is extremely dangerous even potentially deadly to open a septic tank, pumping station or any enclosed space that is part of a wastewater treatment system. This work must be done by a person trained in enclosed space working and rescue procedures who has the necessary equipment.

The action of the bacteria on the organic matter present in the wastewater produces gases such as carbon gas (CO₂), methane gas (CH₄) and sulphuric hydrogen (H₂S). The H₂S present in the septic tank or a pumping station can cause the death of an individual in a matter of minutes. This is why this work must be left to competent personnel.



Pipes are buried near your septic installation. Please speak to your contractor or the technical service of Advanced Enviro-Septic™ in order to take all the necessary precautions prior to digging or undertaking excavation jobs near your septic system.



Please be sure that the covers of the septic tank, the pumping station, and the sampling device are always in place and that they remain accessible at all times for periodic inspections and interventions when necessary.

Advanced Enviro-Septic™ U.S. Brevet nos. 6,461,078; 5,954,451; 6,290,429; 6,899,359; 6,792,977; 7,270,532 and 5,606,786. Other patent pending.

Enviro-Septic® is a trademark of Presby Environmental, Inc. Advanced Enviro-Septic™ is a trademark of Presby Environmental, Inc. Bio-Accelerator^{MC} is a trademark of Presby Environmental, Inc.

User's Guide – Enviro-Septic System

Table of Contents

Introduction	4
The purpose of this document	4
Designation of the Enviro-Septic System	4
Definition of the Enviro-Septic System	5
What to do if a problem occurs?	5
Customer service and Technical support information	5
Certified Contractor	6
Enviro-Septic System Capacity	6
Residential Wastewater	7
Warranty certificate	8
Functioning of the Enviro-Septic System	8
Treatment process of the Enviro-Septic system	8
Diagram of the Enviro-Septic chain of treatment	9
Diagram of the Enviro-Septic system	1
Enviro-Septic System Components	11
Operating the Enviro-Septic System	12
Initial Use	12
Intermittent Use or Prolonged Absences	12
Enviro-Septic System Operating Instructions	12
Wastewater Volume	12
In the bathroom	13
In the kitchen	13
For the laundry	13
Elsewhere in and around the house	13
Chemicals for septic installation	14
Ventilation	14
Heavy machinery and motorized vehicle traffic	14
Vegetation	14
Enviro-Septic System Maintenance	15
Distribution box and flow equalizer	15
Advanced Enviro-Septic System Pipe Rows	16
Elements of the Enviro-Septic System installed in the ground	17
Elements of the Enviro-Septic System appearing above ground	17
Embankment surface above the Enviro-Septic System	18
Owners Responsibilities	19
What to do if water level is high	20
Appendix A - Presby Twenty Year Limited Warranty	21
Appendix B – Information Specific to Your Treatment System	22
Appendix C – Register of the Septic Tank Maintenance	23

User's Guide – Advanced Enviro-Septic Introduction

Thank you for choosing the Advanced Enviro-Septic System for your septic installation. This system was developed to efficiently treat domestic wastewater. Instructions must be followed in order to maintain its treatment performance so that you can make use of it for many years.

Carefully read through this entire document and retain it in your files for future reference.

The purpose of this document

This user guide explains the proper use, procedures and inspections required in order to ensure the proper operation of your Advanced Enviro-Septic System for residential wastewater treatment.

It is the owner's responsibility to ensure that the system is used properly and according to its treatment capacity. It is also their responsibility to respect the rules and regulations in effect regarding associated council and government regulations.

Designation of the Enviro-Septic System

Name: Advanced Enviro-Septic™ Wastewater System

Application Domain: Residential Wastewater (sewage).

Class and treatment type: The Enviro-Septic system meets all the performance criteria requirements of both the Australian standard AS/NZS 1546.3: 2008, and the Queensland Plumbing and Wastewater Code: 2011 (for both Secondary and Advanced Secondary treatment)

The system cannot be used to treat wastewater to make it consumable. It is made to treat residential wastewater to an acceptable level for it to be reintroduced into the environment.

TREATMENT PLANT APPROVAL 02/2025
Plumbing and Drainage Regulation 2019, part 4.



User's Guide –Enviro-Septic

**Definition of
the Advanced
Enviro-
Septic System**

The Enviro-Septic system is composed primarily of two inseparable components: the rows of Advanced Enviro-Septic™ pipe and a layer of system sand.

The Enviro-Septic system must be preceded by a septic tank and a wastewater distribution device. The treated water is drained directly into the soil beneath the treatment system through a soil absorption system.

**What to do if a
problem
occurs?**

If in the course of normal use of your septic system you notice any of the following problems:

- presence of abnormal odours in the house, around the septic system or emanating from sources of drinking water,
- abnormally wet soil, presence of persistent puddles or odours in the area of the septic tank or the Enviro-Septic system,
- slow flushing toilets or other plumbing in the home,
- presence of abnormally abundant vegetation on the surface or around the septic tank or the Enviro-Septic system installation,
- flooding in the area where the Enviro-Septic system is installed,
- erosion of the land fill on or around the Enviro-Septic system,
- alarm from the pumping station if such a device is part of your installation...

...immediately contact your contractor.

**Customer
service and
Technical
support
information**

Please do not hesitate to contact us if you need further information.

We can be contacted at the following coordinates:

Telephone: (07) 5474 4055

Fax: (07) 5335 1691

Email: info@enviro-septic.com.au

Internet site: www.enviro-septic.com.au

Handwritten signature/initials



User's Guide – Enviro-Septic

Certified Contractor The Enviro-Septic System must be installed by a licensed contractor. Certified by Chankar Environmental. Certification is obtained by attending the online "Enviro-Septic Contractor Certification Course". The Advanced Enviro-Septic™ customer service can provide the name of contractors having the proper certification to install Enviro-Septic Systems.

Enviro-Septic System Capacity The capacity of the Enviro-Septic System depends on two elements:

- The number of Enviro-Septic Pipes
- The capacity of the underlying soil to evacuate the treated water.

Tables 1 and 2 present the capacity of each system in relation with the number of pipe installed for a 1 to 6 bedroom residence or other building with a daily flow of 1800 L/d or less. The total volume of wastewater fed to the system must not be more then what is shown in the table.

The system may also be limited by the capacity of the underlying soil to permit the infiltration and evacuation of wastewater. This value should be evaluated by the designer mandated to create the plans and estimates for your septic installation. It is, therefore, important to verify with the designer if the capacity of the soil permits complete infiltration and evacuation of the maximum amount of water able to be treated by the pipes installed.

Number of Advanced Enviro-Septic Pipes (3.0 m each)	Total Length of Advanced Enviro-Septic Pipes (m)	Maximum Daily Flow (L/d)
4	12	360
5	15	450
6	18	540
7	21	630
8	24	720
9	27	810
10	30	900
11	33	990
12	36	1080
13	39	1170
14	42	1260
15	45	1350
16	48	1440
17	51	1530
18	54	1620
20	60	1800

Table 1
 Enviro-Septic hydraulic capacity based on the number of pipes installed

Handwritten signature and date: 16/1/25

TREATMENT PLANT APPROVAL 02/2025
Plumbing and Drainage Regulation 2019, part 4.



User's Guide –Enviro-Septic System

Parameters
Table 2

Testing Parameters	Advanced Enviro-Septic™ Test Results	Qld Secondary	Qld Advanced Secondary	EPA Tertiary	NSF-40 Class 1	BNQ Advanced
CBOD (mg/L)	< 2	20	10	10	< 25	<15
TSS (mg/L)	< 2	30	10	10	< 30	<15
Fecal Coliforms (CFU/100ml)	N/A ** Subsoil Installation	N/A ** Subsoil Installation	N/A ** Subsoil Installation	1000	N/A ** Subsoil Installation	50,000

Residential Wastewater Table 3 indicates the normal characteristics of raw domestic sewage.

Table 3

Parameter	Units	Raw Sewage	Septic Tank Effluent
TSS	mg/L	237-600	50-90
CBOD ₅	mg/L	210-530	140-200
Fecal Coliforms	CFU/100 ml	10 ⁶ -10 ¹⁰	10 ³ -10 ⁶

Source: Tchobanoglous and Burton (1991)

³ The hydraulic capacities shown in table 1 are the same regulation for 1 to 6 bedroom isolated dwellings (clause 1.3). The difference between the minimum number of Enviro-Septic pipe for a similar daily flow between table 1 and 2 come after different security factors that are associated with 1 to 6 bedroom house vs other types of buildings.

Warranty certificate

Advanced Enviro-Septic™ comes with a manufacturer's limited warranty. The warranty details are presented in Appendix A.

Initial:
Date:

User's Guide –Enviro-Septic

Functioning of the Enviro-Septic System

The Enviro-Septic system is a passive technology which facilitates the proliferation of the bacteria responsible for wastewater treatment. It is comprised mainly of two inseparable components: the rows of Advanced Enviro-Septic pipes and a layer of system sand.

The Enviro-Septic system must be preceded by a septic tank and a distribution box (or another method of distribution). It must also be installed over a polishing leaching field.

**Treatment
process of the
Enviro-Septic
system**

The rows of Advanced Enviro-Septic pipes and system sand permit the treatment and distribution of wastewater on the surface of the receiving soil (surface of the polishing leaching field).

The pipes support, first of all, the separation of particles through flotation and decantation. The water is then evacuated through perforations situated all around the pipes and through the pores of the two layers of synthetic media covering the pipes. These membranes facilitate the fixation of the microbial cultures which support wastewater treatment as well as longitudinal distribution.

The layer of sand continues the treatment process and helps in dispersing the water before it infiltrates into the natural soil. In this way, the Enviro-Septic system integrates both functions.

User's Guide –Enviro-Septic

Diagram of the
 Enviro-Septic
 system

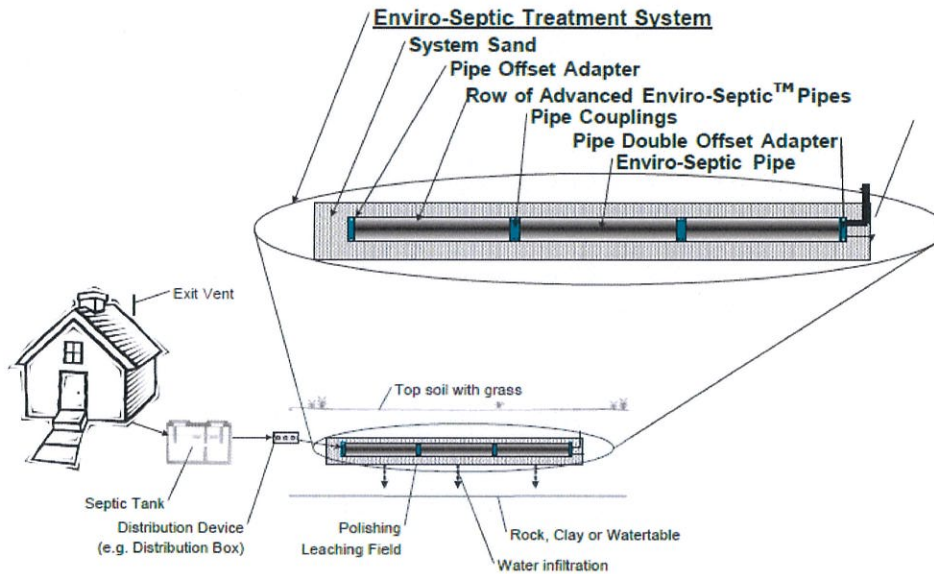

Fig. 4

Enviro-Septic System Components

Your septic installation includes several components. All of these components are parts of the chain of treatment of your installation. Table 4 presents the list of these elements. However it should be noted that some of these are only used when site conditions require them.

The table also presents a summary of inspections required for each component. More detailed information on this subject is presented in the sections that follow.

TREATMENT PLANT APPROVAL 02/2025
Plumbing and Drainage Regulation 2019, part 4.

User's Guide –Enviro-Septic

Table 4 - Enviro-Septic System Components				
Component of the septic system	Function	Follow-up needed	Frequency	Responsible for follow-up
Septic tank	Primary wastewater treatment	Periodic emptying	According to standards and regulations in effect	Owner is responsible to have work done by qualified person
Septic Tank Effluent Filter ⁴	Retention of solids in low pressure pumped applications.	According to manufacturer's instructions.		
Distribution systems if required for larger dual bed systems 3 options A) Gravity Dist box and flow equalizers B) Pressure distribution (feed) system C) Automatic distributing valve	Distributes the septic tank effluent to the rows of Advanced Enviro-Septic.	A) According to water level in the inspection port B) According to the manufacturer's directions. C) According to the manufacturer's directions.	A) As needed	A) Owner
Rows of Advanced Enviro-Septic Pipes.	Distribute and treat wastewater			
Sampling device	To verify the treatment performance of the Enviro-Septic System	Ensure that there is access to this device	Optional	Qualified person
Vent	To allow the circulation of air in the Enviro-Septic System	Ensure that the opening is not blocked	As needed	Owner
System sand	To complete the water treatment process and to improve the drainage	No		
Pumping station (optional)	Lift septic tank effluent to the Enviro-Septic System	According to supplier's specifications		

⁴ The effluent filter is necessary whenever the septic tank is followed by a low pressure distribution system.

LD
16/1/25

User's Guide –Enviro-Septic

Operating the Enviro-Septic System

Initial Use	<p>At the time of installation the septic tank must be filled with clear water.</p> <p>If a pumping station is used, the contractor will verify that it is functioning properly at the time of installation. The home owner must make sure that there is adequate electricity to safely operate the equipment as well as the alarm component.</p> <p>The Enviro-Septic system is now ready for use.</p>
Intermittent Use or Prolonged Absences	<p>The Enviro-Septic system is a passive wastewater treatment system. When properly installed, it requires no particular attention for intermittent use or in the case of prolonged absence.</p>

Enviro-Septic System Operating Instructions

The use and the maintenance of an Enviro-Septic System are relatively simple. In general, respecting the following rules will allow you use of your installation without problems for years to come.

Wastewater Volume	<p>Large quantities of water that leave the house and enter the Enviro-Septic System in a short period of time could have a negative impact on the effectiveness of the treatment and the infiltration of wastewater causing agitation in the septic tank. A quantity of sludge or scum is likely to be put into suspension and be brought towards the system and the infiltration bed.</p> <p>You must ensure that the volume of wastewater entering the Enviro-Septic System is reasonable when compared to the total daily flow the system was designed for.</p> <p>After the installation, if changes are made to the residence (ex. addition of a bedroom), please contact the designer of the Enviro-Septic System. Make sure that the septic system is inspected by a qualified person to determine that it has the necessary capacity to treat and infiltrate the new daily design flow of wastewater being generated.</p>
--------------------------	------------------------------------------------------------------------------------------------------------------------------------------------------------------------------------------------------------------------------------------------------------------------------------------------------------------------------------------------------------------------------------------------------------------------------------------------------------------------------------------------------------------------------------------------------------------------------------------------------------------------------------------------------------------------------------------------------------------------------------------------------------------------------------------------------------------------------------------------------------------------------------------------------------------------------------

User's Guide –Enviro-Septic

In the bathroom

Do:

- immediately repair any leaking faucet or toilet,
- use a reasonable quantity of toilet paper.
- Minimise or avoid bleach, antiseptic disinfectants, and ammonia acids in the system

Do not :

- use disinfectant in tablet (puck) form, whether it is placed in the basin or the tank,
 - throw cigarettes, cigarette butts or medication in the toilet,
 - throw paper towels, paper napkins or other personal hygiene products in the toilet.
-

In the kitchen

Do:

- repair any leaking faucet,
- use dish soap or dishwasher soap that is low in phosphate (0 to 5%),
- use the necessary quantity of soap to do the work. Take note that the necessary quantity is often less than suggested by the manufacturer.
- use biodegradable soap, low-phosphorus or phosphorus free detergents.

Do not :

- use a food waste disposal unit in your sink that is connected to your septic installation. If you do have a waste disposal unit, your septic tank may require more frequent pump out to remove sludge build up
 - dispose of vegetables, meats, fat, oil, coffee beans, citrus products or other products into the septic system.
-

For the laundry

Do:

- use phosphate free detergent, preferably in liquid form. If it is not possible, use biodegradable powder detergent,
 - use the necessary quantity of soap to do the work. Take note that the necessary quantity is often less than that suggested by the manufacturer,
 - minimize the volume of water used for the laundry according to the quantity of clothing to wash,
 - if possible spread your loads of laundry throughout the week
 - prevent harsh chemicals or products entering the system (eg. paint, nappies)
-

Elsewhere in and around the house

Do:

- divert drainage and rain water away from the surface of the Advanced Enviro-Septic System.
- All vents should be mosquito-proofed to prevent mosquitoes from breeding in the tank.
- Roof and surface water should be redirected away from absorption trenches.

Do not :

- discharge water softener backwash into your septic system,
 - discharge any water from swimming pool filters, spas or other appliances that discharge chlorinated water into your septic system.
-

User's Guide –Enviro-Septic

- let water from sump pumps, roof drains (gutters) and drainage pipes. pipes discharge into the septic system,
 - dispose of solvents, paints, antifreeze, engine oil or other chemicals in the septic installation. This includes water used to wash brushes or rollers that were used with latex paint (latex paint contains elements that are harmful to septic system),
 - dispose of animal litter in the septic installation.
-

Chemicals for septic installation

Your Enviro-Septic System does not require any starting chemical, cleaning or other additives. The bacteria that carry out the treatment are naturally present in raw domestic sewage. Any chemicals or additives added to the Enviro-Septic System could possibly kill these bacteria.

Ventilation

It is very important to ensure that good ventilation occurs so that the septic system functions correctly. The vent(s) installed at the ends of the septic system encourage this air circulation. It is important to make sure that the opening is not blocked and that air can circulate freely at all times. Air enters through the vent, circulates through the rows of pipes and the septic tank and travels through the plumbing of the house to exit through the roof vent.

The owner must be sure to have a roof vent and to keep it clear at all times. When a pumping station is used, a bypass pipe or an extra vent must be used to ensure proper ventilation of the system.

Heavy machinery and motorized vehicle traffic

No vehicles or heavy machinery must be driven on a septic system, whether it is before, during or after its construction. Heavy machinery or motorized vehicle traffic on the soil closes the natural pores of the soil which reduces its permeability and allows for pounding and the accumulation of water.

Vegetation

The surface of the septic system must be planted with grass. The grass must be cut regularly in order to encourage growth without the use of fertilizers. Vegetation cover contributes to the elimination of nitrogen and phosphorus.

It is important not to plant trees or other plants with invasive roots within the proximity of the septic installation (minimum distance 3 meters).

User's Guide – Enviro-Septic

Enviro-Septic System Maintenance

Septic Tank Maintenance

The septic tank preceding the Enviro-Septic System must be pumped out regularly (every 3-5 years for normal residential use or sludge exceeds 2/3 of the tank). Verify the current regulation, or get in touch with relevant council or government authorities.

If the septic tank is not emptied regularly, an increasingly large amount of solids and grease in suspension will leave the septic tank and end up in the treatment system and in time the performance of the Enviro-Septic System may be affected.

At all times, a professional using the proper equipment must carry out the pumping out of a septic tank

The owner is responsible to ensure his septic tank is pumped out according to council regulations. This work should always be done by a qualified person since it can be very dangerous to open a septic system without first taking the necessary precautions.

Note: It is the home owner's responsibility to make sure that at all times the septic tank lids are in their proper position and securely fastened. A lid that is not installed correctly can be harmful to the operation of the Enviro-Septic System.

Pre-filter (Septic tank effluent filter)

Effluent filter equipment is not necessary at the exit of the septic tank⁵. It is mandatory when a low pressure distribution system is used between the septic tank and the Advanced Enviro-Septic pipes.

The effluent filter must be cleaned according to the maintenance and inspection procedures provided by the manufacturer.

⁵ The effluent filter is necessary whenever the septic tank is followed by a low pressure distribution system.

TREATMENT PLANT APPROVAL 02/2025
Plumbing and Drainage Regulation 2019, part 4.



User's Guide –Enviro-Septic

**Advanced
Enviro-Septic
Pipe Rows**

Under normal use, the rows of Advanced Enviro-Septic pipe do not require maintenance. It is normal to find fluctuation of the water level in the pipes. If the water level reaches 260 mm, a rejuvenation of the Enviro-Septic System must be considered. A qualified person⁶ must carry out this procedure.

⁶ There may be costs related to this operation, if the problem is due to improper use of the system or due to a design or installation problem.

RA
16/1/25

User's Guide –Enviro-Septic

Vent	The owner must however ensure that nothing prevents the circulation of air. There must also be a difference of at least 3 meters, at all times, between the entry vent situated at the extremity of the Enviro-Septic system and the exit vent usually located on the roof.
System Sand	There is no maintenance to be done on the system sand during normal use of the Enviro-Septic System.
Pumping station or low pressure distribution system	In certain cases, the site constraints require the use of a pumping station or a low-pressure distribution system to evenly distribute the water. The owner is then responsible to comply with the manufacturer's scheduled maintenance requirements of this equipment.
Embankment surface above the Enviro-Septic System	The surface located above the Enviro-Septic system must be covered with herbaceous vegetation. A slight slope must be given to the surface in order to help the drainage of rainwater towards the outside of the system. The grass must also be cut regularly. Finally, any depression that could be created with time must be filled in order to avoid any accumulation of water above the system and to prevent erosion.

User's Guide –Enviro-Septic

Owner's Responsibilities

**Owner's
Responsibilities**

The owner is responsible for:

- using the Enviro-Septic System according to the instructions presented in the user guide.
- pumping out the septic tank according to the regulations in effect.
- maintaining the effluent filter (if present), the pumping station, the pressure distribution system or the automatic wastewater distributing valve according to manufacturer's specifications and recording the information if this equipment is part of the system.
- ensuring that the vent openings are clear of any obstacle.
- providing access at all times to the Enviro-Septic system.
- adhering to the requirements of the applicable rules and regulations, in particular with regards to the discharge standards of the system to the environment.

**Qualified
person**

The qualified person that performs the maintenance or the inspection of an Enviro-Septic System is a person who was trained and certified by Chankar Environmental or has certification from Presby Environmental to perform the tasks associated with the Enviro-Septic system. Chankar Environmental trains these people to carry out the inspections of the system, perform adjustments to the equalizers and/or carry out the rejuvenating procedure.

To obtain the name of a qualified person in your area, contact our customer service department on (07) 474 4055).

For maintenance on the pumping station and the low pressure distribution system, the owner must refer to the user guide specified by the manufacturer of these systems.

The pumping out of the septic tank must be performed by a company specializing in that field. Check with your council for the companies in your area that are qualified to do this work.

User's Guide –Enviro-Septic

Appendix A- Presby Twenty Year Limited Warranty



PRESBY ENVIRONMENTAL, INC.
INNOVATIVE SEPTIC TECHNOLOGIES

This Twenty Year Limited Manufacturer's Warranty is provided by the Manufacturer, Presby Environmental, Inc., a New Hampshire corporation having a mailing address of 143 Airport Rd., Whitefield, New Hampshire, 03598 (hereinafter called "Presby"). This Warranty applies only to Presby Products sold by or through its duly authorized distributor Chankar Environmental an Australian corporation having a mailing address of Unit 6-62 Rene St, Noosaville, Qld 4566 (hereinafter called the "Distributor"). "Presby Products" means Presby's Enviro-Septic® leaching systems and Preesby Maze® with the required accessories (couplings, offset adaptor).

Warranty: Presby warrants that Presby Products are free from defect for twenty years from the date of installation but in no event more than twenty-one years from the date of manufacture. Product Defects means defects or damage to the Products caused by or occurring during the manufacturing process. This Warranty does not cover or apply to damages to the Products caused by or resulting from transit or from accident, misuse, abuse, neglect, storage, installation, repair, maintenance or from use other than normal and ordinary use of the Products. This Warranty does not apply to damages to the Products caused by or resulting from failure to install or use the Products in accordance with distributor's instructions which have been approved by Presby or failure to properly inspect and maintain the Products.

Warranty Registration, Claim Process and Remedy: Any claim under the Warranty must be in writing and received by the distributor within thirty days of the date when the facts giving rise to such claim under this Warranty become known or are otherwise discovered. The distributor must be provided with an opportunity to inspect the Products as installed. Failure to comply with these requirements renders the Warranty null and void. If, during the Warranty period, the distributor and Presby find and determine that defects in Products exist, then the distributor and Presby's sole and exclusive obligation is to either repair the Products or provide replacement Products. The distributor and Presby, in their discretion, shall determine whether to repair the Products or provide replacement Products. The distributor and Presby shall have no obligation to remove any defective Products or to install any replacement Products. The distributor and Presby shall not be liable or responsible for any other damages or claims arising from or relating to defective Products, including but not limited to claims for general, consequential, or incidental damages, lost profits, or attorney fees.

Disclaimer: The distributor and Presby otherwise make no express warranty concerning the Products and the distributor and Presby disclaims any and all warranties, express or implied. Except as stated herein, there are no warranties express or implied, and the distributor and Presby do not warrant that the goods are merchantable or fit for any particular purpose. Any claim or controversy relating to this Warranty, or to matters of place of contracting, interpretation, performance or breach thereof, shall be brought in and adjudged in accordance with the applicable laws of state of New Hampshire.



TREATMENT PLANT APPROVAL 02/2025
Plumbing and Drainage Regulation 2019, part 4.

User's Guide –Enviro-Septic

Appendix B - Information Specific to Your Treatment System

**Information on
your Enviro-
Septic System**

Installation date: _____

Contractor /Engineer: _____

Contractor: _____

Plumbing inspector: _____

Number of rows of pipes: _____

Hydraulic capacity (L/d): _____

Number of 3m pipes per row: _____

Water Distribution

- Distribution box
- Wastewater distributing valve

Septic tank capacity: _____

Notes

Initial:
Date:
16/1/25

TREATMENT PLANT APPROVAL 02/2025
Plumbing and Drainage Regulation 2019, part 4.

Attachment 2 – AES – Product Specifications and Schematic diagram

Chankar Environmental

3

APPLICATION FOR PRODUCT ACCREDITATION
(Onsite Wastewater Treatment System)

ADVANCED ENVIRO-SEPTIC (AES) SYSTEM COMPONENTS

Advanced Enviro-Septic™ is an effective, passive onsite wastewater treatment system for residential, commercial and community use. Each AES unit is a 3 meter long engineered pipe with outer layers of randomly placed fibres, bio accelerator and non-woven geotextile fabric. The geotextile fabric is sewn together to hold the pipe, fibres and the bio accelerator for easy handling.

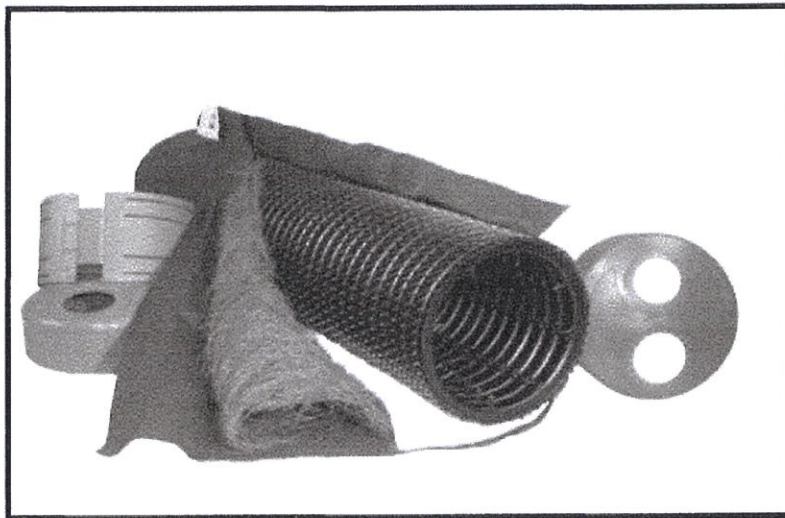

Main components of AES system include;

1. AES Pipe unit (3 meter long pipe) – incorporates corrugation, perforated holes and internal skimmer taps
2. AES Couplings – patented connector to join the AES pipe units as per the design requirements.
3. AES Offset Adaptor – 308mm diameter cap that has 1 x 92mm pre cut hole 9 (open to suit 100mm PVC pipe). This 92mm hole is for connection to the septic tank outlet and for raised connection between rows of AES pipes. Required number of offset adaptor depends on the resign requirements.
4. Oxygen Demand Vent – 100mm vent cowl with mosquito proof screen.

Specifications of AES Components

Initial:
Date:

TREATMENT PLANT APPROVAL 02/2025
Plumbing and Drainage Regulation 2019, part 4.

Chankar Environmental

4

AES Pipe		
Part. AES-Q	Length	3 metre
	Diameter	0.3 metre
	No. of Corrugation / 3m	90
	No. of Skimmer Tap / 3m	720
	Bio Accelerator	0.76 square metre
	Fibers	2.83 square metre
	Geotextile Fabric	2.83 square metre
AES Coupling		
Part. AES-ESC	Diameter	0.308 metre
	Width	0.178 metre
	No. of Engagement Ridges	2
AES Offset Adaptor		
Part. AES-ESO	Diameter	0.310 metre
	Width	0.12 metre
	Inlet / Raised Connection	0.92mm
	No. of Locking Taps	4
Oxygen Demand Vent Cowl		
Part. AES-ODV	Diameter	0.1metre
	Height	0.105 metre

Each unit of AES system pipe is 3 meter long and 0.3 metre in diameter. These pipes can be connected in a number configurations depending on the site and soil constrains. Advanced Enviro-Septic Design Calculator provided by the Chankar Environmental is an excellent tool for working out design configurations and bill of materials.

Where required land application area is greater than the system basal area, a layer of system sand extension is needed at the adjoining land application interface.

 Initial:
 Date:



ADVANCED ENVIRO-SEPTIC™ WASTEWATER TREATMENT SYSTEM

TEN STEPS OF WASTEWATER TREATMENT: ADVANCED ENVIRO-SEPTIC™ TREATS EFFLUENT MORE EFFICIENTLY TO PROVIDE LONGER SYSTEM LIFE AND TO PROTECT THE ENVIRONMENT.

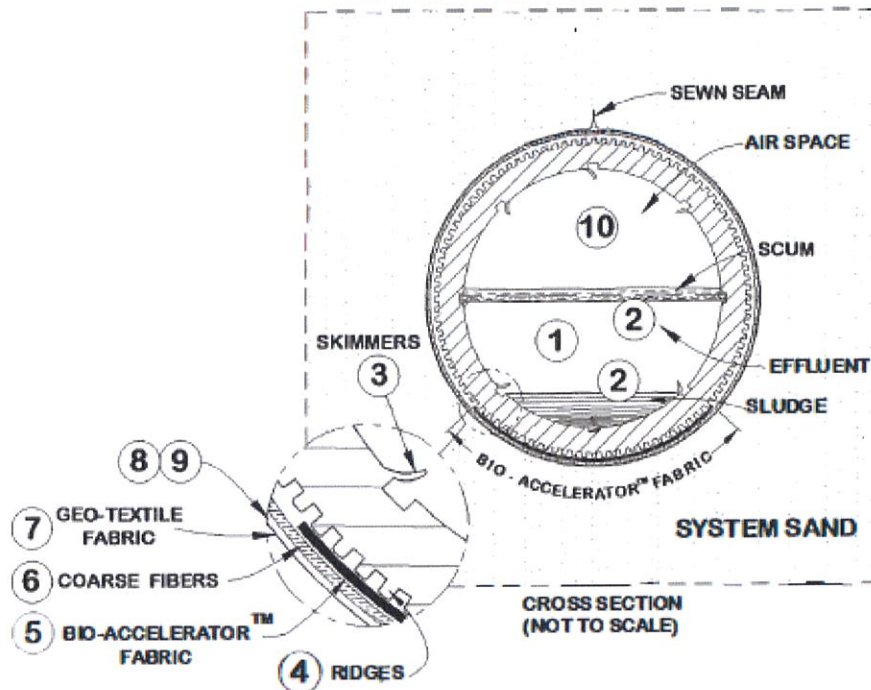

- STAGE 1: WARM EFFLUENT ENTERS THE PIPE AND IS COOLED TO GROUND TEMPERATURE.
- STAGE 2: SUSPENDED SOLIDS SEPARATE FROM THE COOLED LIQUID EFFLUENT.
- STAGE 3: SKIMMERS FURTHER CAPTURE GREASE AND SUSPENDED SOLIDS FROM THE EXITING EFFLUENT.
- STAGE 4: PIPE RIDGES ALLOW THE EFFLUENT TO FLOW UNINTERRUPTED AROUND THE CIRCUMFERENCE OF THE PIPE AND AID IN COOLING.
- STAGE 5: BIO-ACCELERATOR™ FABRIC SCREENS ADDITIONAL SOLIDS FROM THE EFFLUENT AND DEVELOPS A BIOMAT WHICH PROVIDES TREATMENT AND ENSURES ACCELERATED BIOMAT DEVELOPMENT.
- STAGE 6: A MAT OF COARSE RANDOM FIBERS SEPARATES MORE SUSPENDED SOLIDS FROM THE EFFLUENT.
- STAGE 7: EFFLUENT PASSES INTO THE GEO-TEXTILE FABRICS AND GROWS A PROTECTED BACTERIAL SURFACE.
- STAGE 8: SAND WICKS LIQUID FROM THE GEO-TEXTILE FABRICS AND ENABLES AIR TO TRANSFER TO THE BACTERIAL SURFACE.
- STAGE 9: THE FABRICS AND FIBERS PROVIDE A LARGE BACTERIAL SURFACE TO BREAK DOWN SOLIDS.
- STAGE 10: AN AMPLE AIR SUPPLY AND FLUCTUATING LIQUID LEVELS INCREASE BACTERIAL EFFICIENCY.

TREATMENT PLANT APPROVAL 02/2025
Plumbing and Drainage Regulation 2019, part 4.



ITEM #	DESCRIPTION
1	PLASTIC PIPE
2	BIO-ACCELERATOR FABRIC (BOTTOM THIRD OF PIPE)
3	RANDOMLY ORIENTED PLASTIC FIBER
4	GEO-TEXTILE FABRIC
5	SEWN SEAM (ALWAYS ORIENTED UP)

The information disclosed in this document, including all designs and related materials, is the valuable property of Presby Environmental, Inc. (PEI) and/or its licensors. PEI and/or its licensors, as appropriate, reserve all patent, copyright and other proprietary rights to this document, including all design, manufacturing, reproduction, use, and sales rights there to, except to the extent said rights are expressly granted to others.

	Presby Environmental, Inc. 143 Airport Road Whitefield, NH 03598 800-473-5298 <i>The Next Generation of Wastewater Technology</i>		
	PART NAME: ADVANCED ENVIRO-SEPTIC PIPE		
DRAWN BY: PEI	DATE: Feb 26, 2013	SCALE: NONE	SHEET: 1 OF 5

Initial:
 Date:
16/1/25

TREATMENT PLANT APPROVAL 02/2025
Plumbing and Drainage Regulation 2019, part 4.

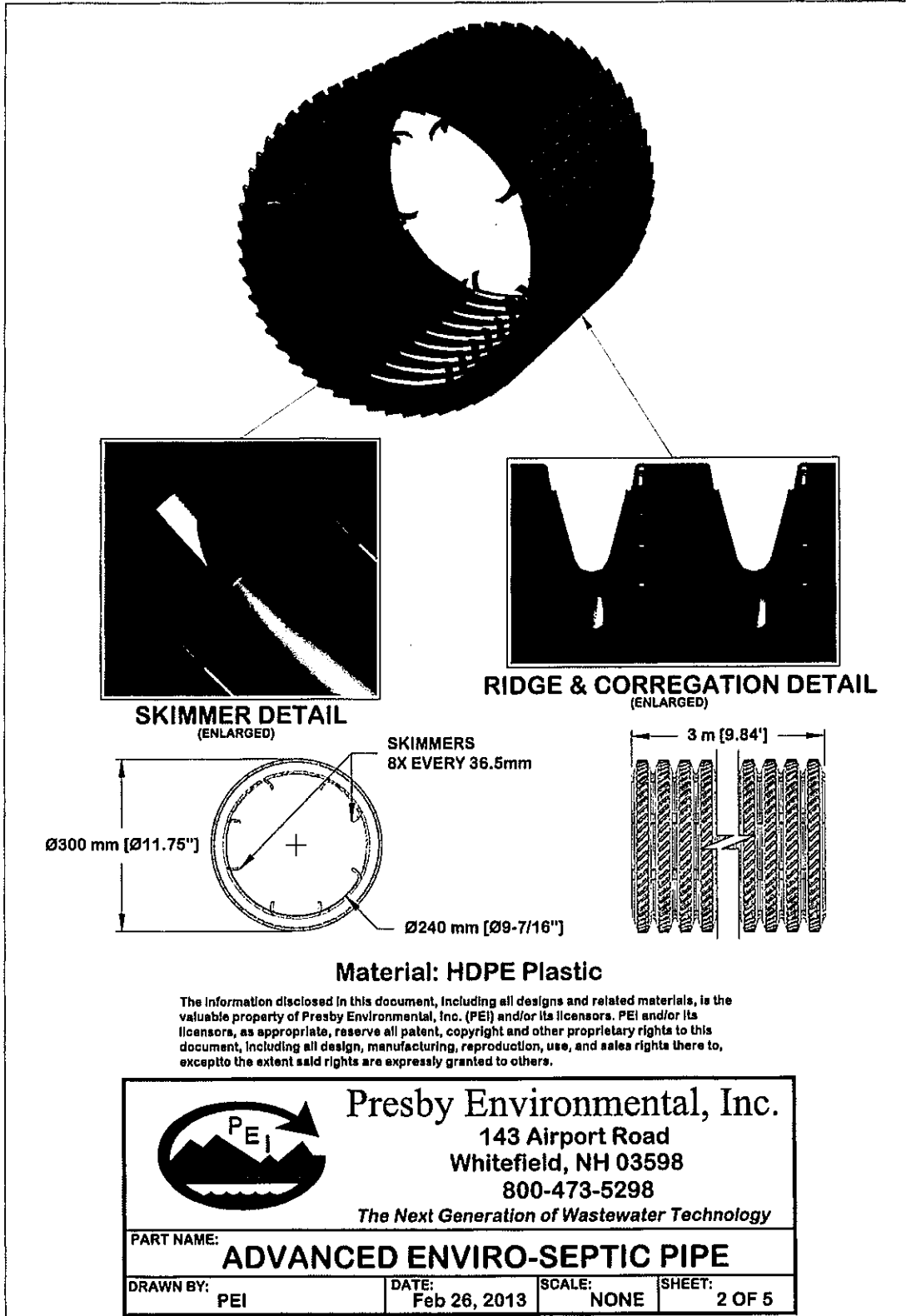



TREATMENT PLANT APPROVAL 02/2025
Plumbing and Drainage Regulation 2019, part 4.

Handwritten initials and date: *AW 06/1/15*

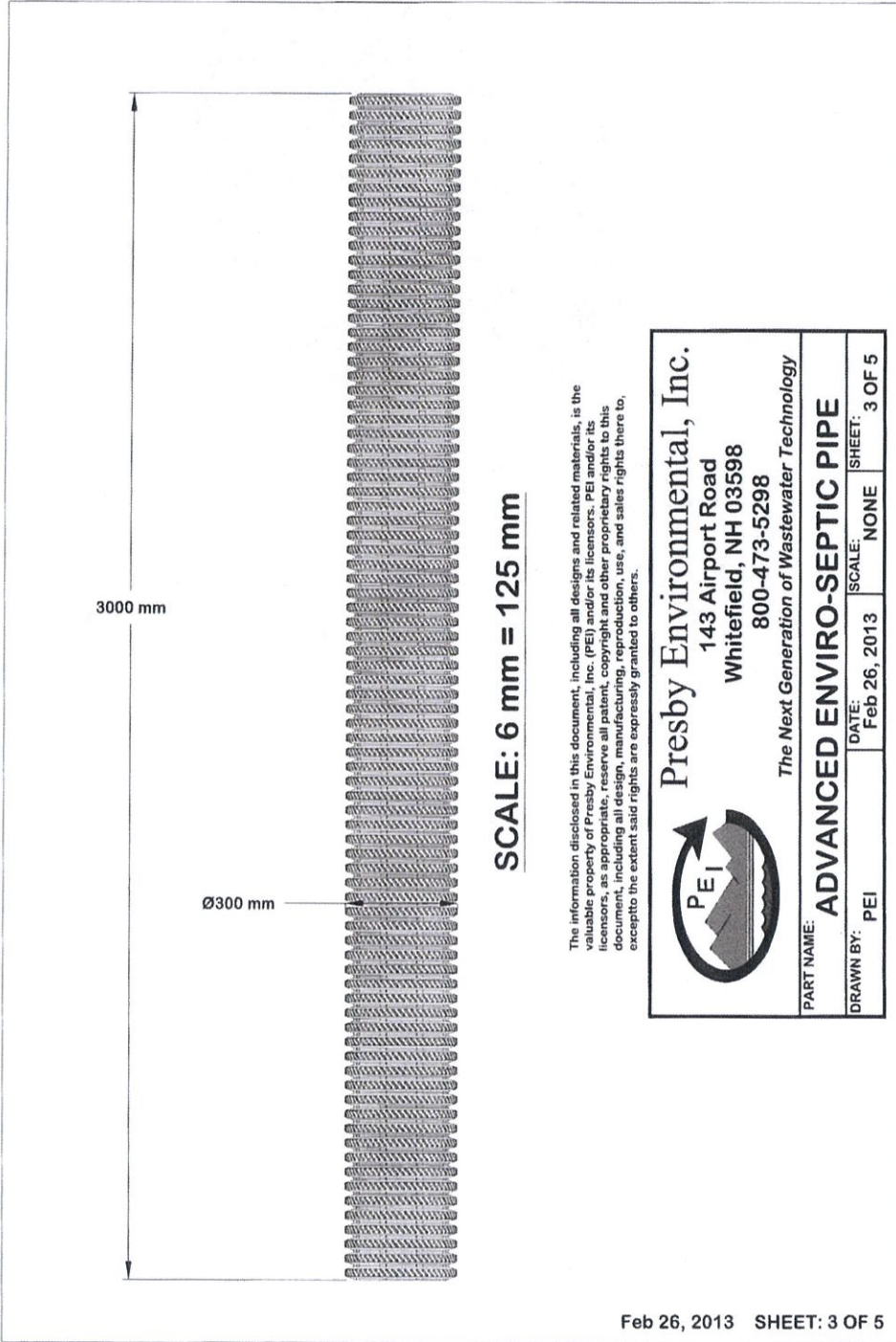

Initial:
Date:

TREATMENT PLANT APPROVAL 02/2025
Plumbing and Drainage Regulation 2019, part 4.

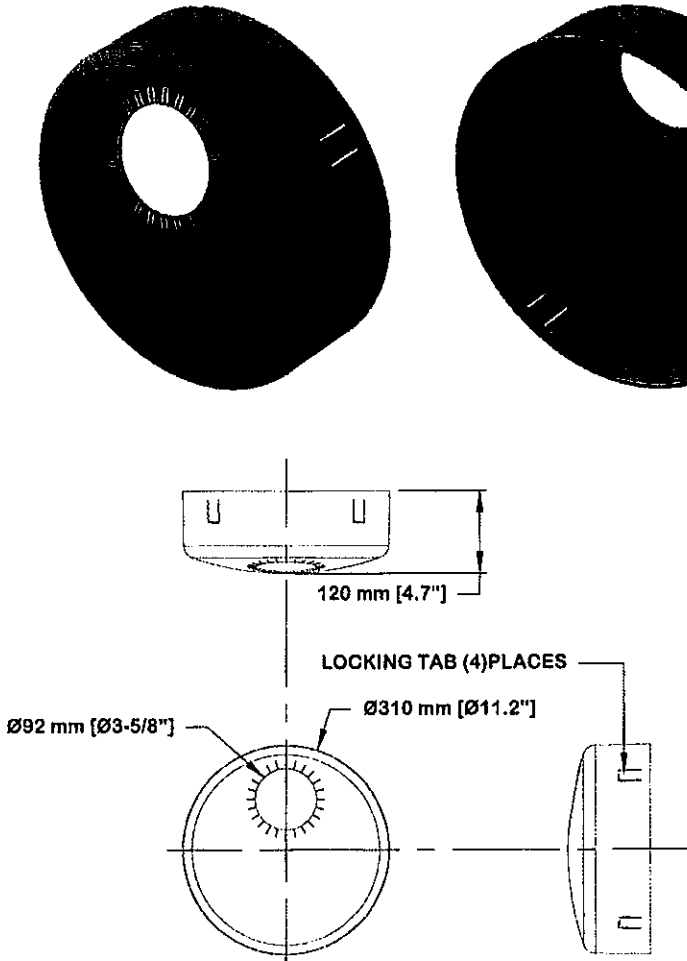

MATERIAL: PLASTIC

The information disclosed in this document, including all designs and related materials, is the valuable property of Presby Environmental, Inc. (PEI) and/or its licensors. PEI and/or its licensors, as appropriate, reserve all patent, copyright and other proprietary rights to this document, including all design, manufacturing, reproduction, use, and sales rights there to, except to the extent said rights are expressly granted to others.

	Presby Environmental, Inc. 143 Airport Road Whitefield, NH 03598 800-473-5298 <i>The Next Generation of Wastewater Technology</i>		
	PART NAME: OFFSET ADAPTER		
DRAWN BY: PEI	DATE: Feb 26, 2013	SCALE: NONE	SHEET: 4 OF 5

Initial:
Date:

TREATMENT PLANT APPROVAL 02/2025
 Plumbing and Drainage Regulation 2019, part 4.

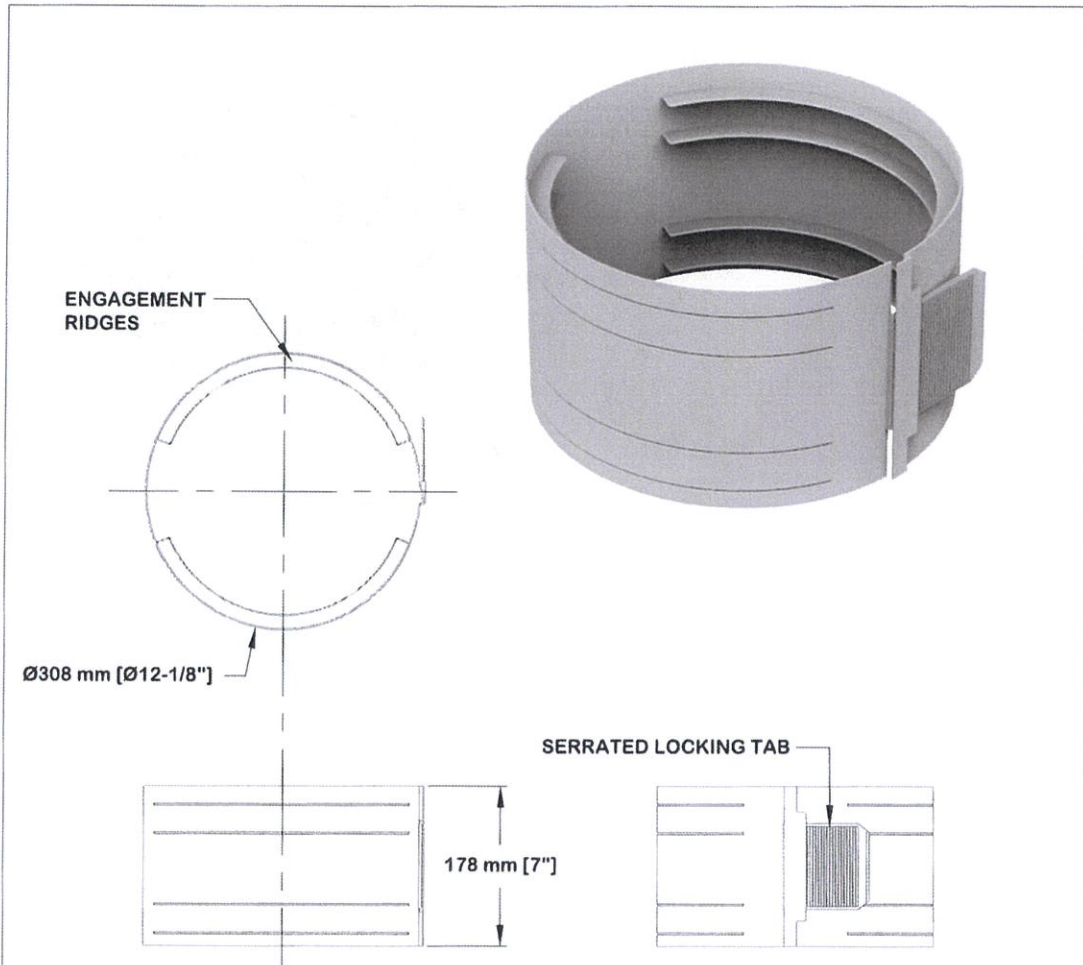

MATERIAL: PLASTIC

The information disclosed in this document, including all designs and related materials, is the valuable property of Presby Environmental, Inc. (PEI) and/or its licensors. PEI and/or its licensors, as appropriate, reserve all patent, copyright and other proprietary rights to this document, including all design, manufacturing, reproduction, use, and sales rights there to, except to the extent said rights are expressly granted to others.

	Presby Environmental, Inc. 143 Airport Road Whitefield, NH 03598 800-473-5298 <i>The Next Generation of Wastewater Technology</i>		
	PART NAME: COUPLING		
DRAWN BY: PEI	DATE: Feb 26, 2013	SCALE: NONE	SHEET: 5 OF 5

Initial: [Signature]
 Date: 16/1/25

TREATMENT PLANT APPROVAL 02/2025
Plumbing and Drainage Regulation 2019, part 4.



Advanced Enviro-septic Design Calculator V8.3

"Always the BEST Option" until site and soil conditions rule it out.

Site Address	Must have Lot or Street number, Address and Post Code	
Client Name	Client details and Contact Phone Number	
Designed By Name	Designers Ph Number	QBSA Lic. Number
Lic Plumber Name	Plumber Ph Number	Plumb / Drainer Lic Number
Council Area	AES Certif Number	Date

This Calculator is a guide only, receiving soil classification, surface water, water tables and all other site constraints addressed by the design.

System Designers site and soil calculation data entry	IMPORTANT NOTES
Is this a new home installation Y or N	>> CHECK THE CONDITION & CAPACITY OF THE EXISTING SEPTIC TANK AS PART OF THIS DESIGN. Remove outlet filters, if you DO NOT REMOVE the filter you will need to instal a 100mm, HIGH and LOW VENTS on the AES system.
Number of person	
Daily Design Flow Allowance Litre/Person/Day	
Number of rows required to suit site constraints	>> The maximum lth of a single AES pipe run is 30 meters
Infiltration surface Soil Category as established by site and soil evaluation. CATEGORY	>> Category may require design considerations. Ref AS1547
Design Loading Rate based on site & soil evaluation DLR (mm/day)	>> Soil conditioning may be necessary. Ref AS1547 & Comments.
Bore log depth below system Basal area	>> Min depth below basal area is 600 mm to establish water table or restrictive layer
Enter System footprint Slope in % for standard AES systems to calculate extension	>> Consideration required for Sloping sites. Ref AS1547. refer comment.
Is this design a gravity system with no outlet filter? Y or N	>> A House Vent & L*W VENT required on this system

PLEASE CHECK YOU HAVE FALL FROM TANK TO AES SYSTEM PIPES

COMMENTS -> * The outcome must be important to everyone. *

- Ripping of receiving surface is required in clay soil structures in Cat 4,5,6. In addition refer to AS 1547. Always excavate a trial pit parallel to the site slope/AES pipe.
- Specialist soils advice and special design techniques will be required for clay dominated soil having dispersive or shrink/swell behaviour. Refer AS1547
- Designers need to be familiar with special requirements of Local Authorities. IE - Minimum falls from Septic tanks to Land application areas. etc
- Plumbers are reminded that good construction techniques as per AS1547 are especially important in the above soil types. Refer AS1547 & AES Installation Instructions

AES System Calculator Outcomes		AES dimensions	
Total System load - litres / day	l/d	AES System	System Extension
Min Length of AES pipe rows to suit loading	m	Lth m : (L)	
Number of FULL AES Pipe lengths per row	lths	Width m:(W)	
Total Capacity of AES System pipe in Litres	ltr.	Sand Depth :	
		Area m2	

DO YOU WISH TO USE CUT LENGTHS OF PIPE IN THIS DESIGN? (ENTER Y)

IF YOU WISH TO USE A TRENCH EXTENSION DESIGN OPTION ENTER "Y" Enter Custom Width m >

AES INFILTRATION FOOT PRINT AREA - $L = Q / (DLR \times W)$	Length	Width	Minimum AES foot print required .
for this Basic Serial design is	x	=	m2 total

Code	AES System Bill of Materials	Chankar Environmental Use Only
AES-PIPE	AES 3 metr Lths required	
AESC	AESC Couplings required	
AESO	AESO Offset adaptors	
AESODV	AES Oxygen demand vent	
AES-IPB	AES 90mm Inspection port base	
AES Equ	AES Speed Flow Equaliser	
	TOTAL SYSTEM SAND REQUIRED (Guide Only)	m3

PLEASE email your AES CALC and Drawings to DESIGNREVIEW@ENVIRO-SEPTIC.COM.AU Designreview@enviro-septic.com.au

- > The AES Calculator is a design aid to allow checking of the AES components and configuration and is a guide only. Site and soil conditions referencing the AS 1547 standard are calculated and designed by a Qualified Designer.
- > Chankar Environmental has no responsibility for the soil evaluation, loading calculations or DLR entered by the designer for this calculator.
- > AES pipes can be cut to length on site. They are supplied in 3 meter lths only.

Initial:
Date:

